

elegance

*Presenting Elegance Water Heaters to
elevate your bathroom décor*



- Sleek Design
- High energy efficiency

elegance



Elegance water heaters feature BEE 4 star rating and saves on energy costs. With its compact size, it can easily fit in lofts and above false ceilings of your bathroom. Blue Diamond® Glass lined Tank and Glass coated Incoloy heating element ensures longer life even in toughest water conditions.

Specifications

MODEL	Elegance	
Volume [L]	15	25
Power [W]	2000	
Voltage/Frequency [V/Hz]	230~/50	
Rated water pressure [Bar]	8	
Dimensions	A [mm]	338
	B [mm]	704
	C [mm]	352
Net Weight [kg]	11.6	15.5
Color	White	
BEE Star Rating	4	

Note: A. O. Smith reserves the right to amend or modify the specifications and features at any time, as and when required without any prior notification.

Elegance models are available in both with right-hand side and left-hand side inlet outlet configuration.

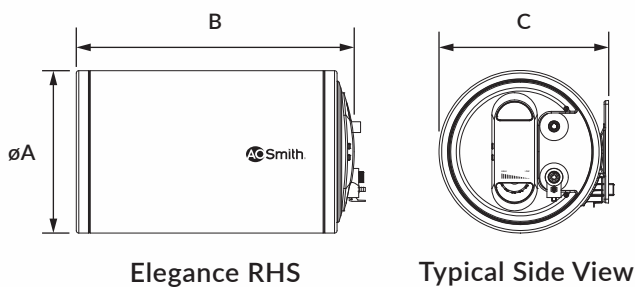

Benefits



Compact size ergonomically and aesthetically designed water heater



High energy efficiency with BEE 4 Star rating



Longer life in toughest water conditions with Blue Diamond® glass lined tank



Long lasting performance with glass coated incoloy heating element



Double Protection for your family with Thermal cutout and safety valve



Long-lasting Anode Rod with 2X lifespan even in hard water conditions.



Manufactured by
A. O. Smith India Water Products Private Limited
 Plot No. 300, Phase - II, KIADB Industrial Area, Harohalli,
 Kanakapura Taluk, Ramanagara District, Karnataka - 562 112, India.
 CIN: U31909KA2006PTC040282

Call **1800 103 2468 / 1860 500 2468** or visit www.aosmithindia.com

<https://www.facebook.com/aosmithin> | <https://twitter.com/AOSmithin> | <https://instagram.com/aosmithindia>



Call 1800 103 2468 / 1860 500 2468 or
visit www.aosmithindia.com



Plot No. 300, Phase - II, KIADB Industrial Area, Harohalli, Kanakapura Taluk,
Ramanagara District, Karnataka - 562 112, India. CIN: U31909KA2006PTC040282
www.aosmithindia.com | <https://www.facebook.com/aosmithin> | <https://twitter.com/AOSmithin>

AOS/NWH_R1/03/21



World's No.1
MANUFACTURER OF WATER HEATERS





SAY HELLO TO A. O. SMITH.

Founded in 1874 by Charles Jeremiah Smith, the A. O. Smith Corporation began as an engineering company in Milwaukee, Wisconsin. Today, we are the global leaders in making water heaters. This drives our pursuit for excellence when it comes to water purifiers as well. For the past 145 years, our singular purpose has been to create stellar products that deliver the best performance with the best technology. And to this day, we live strongly by that belief.

OVER A CENTURY OF INNOVATION.

A. O. Smith enjoys a rich history of achievements. A glimpse at our 145-year history reveals numerous engineering and technical achievements.



1874

The Smith family started a small mechanical shop in Milwaukee, North America.



1906

A. O. Smith was North America's largest automobile frame manufacturer.



1936

A. O. Smith patents the glass-lined water heater.



1995

Reach into the Asian market by entering two joint-ventures in China.

1889

The company enters the bicycle industry.



1927

A. O. Smith was a leading supplier of line pipe.



1954

The water heater division introduces the first glass-lined commercial water heater, the A. O. Smith Burkay® B-65.



2010

State-of-the-art plant set-up in Harohalli, Bengaluru in 2010.



The Blue Diamond® Story.

A. O. Smith was credited with the invention of the glass-lined water heater tanks in 1936. After this, the next breakthrough was the Blue Diamond® technology in 2004. In this technology, a specially formulated glass frit is bonded to the steel through a complex process that is carried out at over 800°C. The Blue Diamond® Glass-Lining technology reduces scaling accumulation on the tank caused by minerals, corrosion due to hard water and leakage of heat into the atmosphere. It also enhances the strength and durability of the tank.

All A. O. Smith water heaters come with Blue Diamond® Glass-Lining technology, replacing the earlier stainless steel water heaters that were prone to rusting, corrosion and scaling due to the contact between hot water and steel.

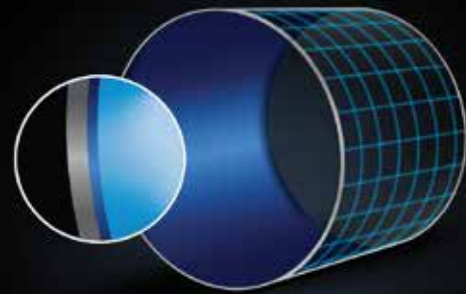

This **Blue Diamond® technology** provides twice the corrosion resistance compared to industry standards and increases the life span of the tank.

Setting Benchmarks.



HeatBot®

UPGRADE TO THE ART OF SMART BATHING



Redefine your bathing experience with the new Heatbot that rejuvenates and relaxes your senses. Elevate your bath and bathroom with this pure art, backed with intelligent design and functionality.





HeatBot®
15/25 (L)

FUTURE-READY



Easy Operation with
Wireless Remote



Hot Water Ready at anytime
with Smart Timer Mode



Track your Energy Use with
Energy Meter



Sleek & Modern Masterpiece to
Elevate your Bathroom

WORRY-FREE



Blue Diamond® Glass-Lined Tank for
2X corrosion resistance.



7-year warranty on tank. 2+2 year warranty
on Glass Coated Heating Element.



Long-lasting Anode Rod with
2X lifespan even in hard water conditions.



Double Protection with Thermal Cut-Out and
Multi-function Safety Valve.

ECO-FRIENDLY



BEE 5-star rated with Advanced PUF
Technology for Power Savings.
Perfect if you want to go green.



Convenient Display &
Intuitive Controls



HeatBot®

Digital Model : SZS-DG

Capacity : 15L, 25L

Product Color : White | Silver

Power(KW) : 2

Rated Water Pressure: 8 Bars



Mechanical Model : SZS

Capacity : 15L, 25L

Product Color : White | Silver

Power(KW) : 2

Rated Water Pressure: 8 Bars



Storage Water Heaters

Product Dimensions

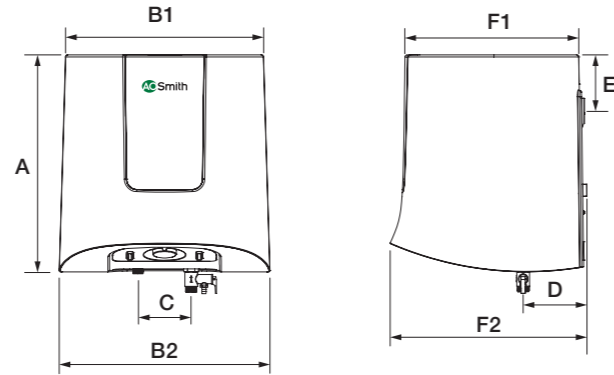

All Dimensions in mm

Model Name	A	B1	B2	C	D	E	F1	F2
SZS-DG-015 SZS-015	408	372	395	100	120	100	328	370
SZS-DG-025 SZS-025	486	421	444	100	142	139	361	408





IT'S ABOUT TIME - EXPRESS HEAT SERIES.

Our Express Heat series values your time. This is why they give you hot water 33% faster compared to ordinary water heaters of 2KW. At a temperature of your choice, you'll be surprised at the amount of time these water heaters can save for you.

SGS-PLUS



Capacity : 6L, 10L, 15L, 25L
Product Color : White Ivory
Panel Color : Red
Power(KW) : 3
Rated Water Pressure: 8 Bars



Longer life in toughest water conditions with Blue Diamond® glass lined tank



Glass-Coated Incoloy Heating Element
Resistant to scale formation.



Long-lasting Anode Rod
2X lifespan as compared to normal magnesium rod.



Express Heat
33% faster heating than 2 kw water heaters. Get hot water quicker.



Temperature Control Knob
Easy temperature settings.



Advanced PUF Insulation
High energy efficiency and power savings.



Inner Tank	Extended Warranty* on Heating Element	Comprehensive
7 years	2+2 years	2 years

Storage Water Heaters

Product Dimensions

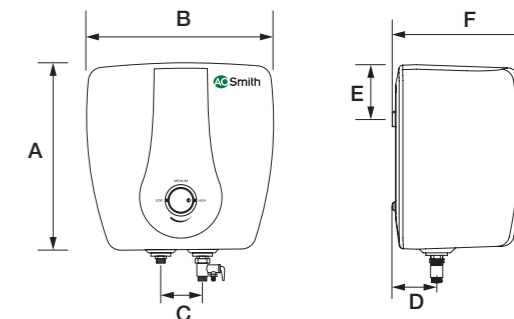

All Dimensions in mm

Model Name	A	B	C	D	E	F
SGS-PLUS-006	317	317	100	85	105	258
SGS-PLUS-010	373	373	100	95	120	277
SGS-PLUS-015	373	373	100	125	130	348
SGS-PLUS-025	444	444	100	125	135	383

A. O. Smith ColourMatch System®

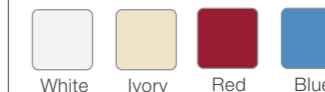

* Refer page 32 for more details

Colours shown are only indicative and may vary from actual colours available.



AESTHETICS AND PERFORMANCE REDEFINED

With its best in class design, Blue Diamond Glass lining coupled with maximum energy efficiency, SDS PLUS range of water heaters are built to last a lifetime.

SDS-PLUS



Capacity : 6L, 10L, 15L, 25L
Product Color : White | Ivory
Panel Color : Blue
Power(KW) : 2
Rated Water Pressure: 8 Bars



Longer life in toughest water conditions with Blue Diamond® glass lined tank



Maximum energy savings with BEE 5 Star rating



Superior performance with incoloy heating element



Temperature Control Knob
Easy temperature settings.



Long-lasting Anode Rod
2X lifespan as compared to normal magnesium rod.



Advanced PUF Insulation
High energy efficiency and power savings.



Inner Tank	Extended Warranty* on Heating Element	Comprehensive
7 years	2+2 years	2 years

Storage Water Heaters

Product Dimensions

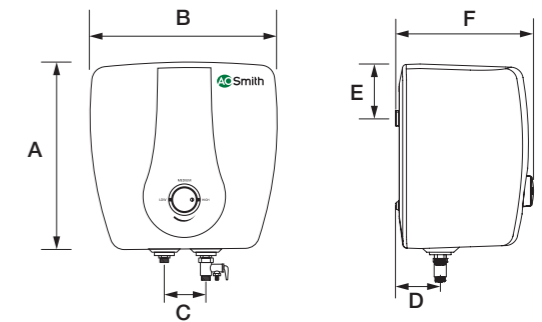

All Dimensions in mm

Model Name	A	B	C	D	E	F
SDS-PLUS-006	317	317	100	85	105	258
SDS-PLUS-010	373	373	100	95	120	277
SDS-PLUS-015	373	373	100	125	130	348
SDS-PLUS-025	444	444	100	125	135	383

A. O. Smith ColourMatch System®



* Refer page 32 for more details

Colours shown are only indicative and may vary from actual colours available.



BOLD AND DURABLE

With superior Incoloy heating element, the SAS PLUS series is designed to perform the best, even in toughest of water conditions.

SAS-PLUS



Capacity : 6L, 10L, 15L, 25L
Product Color : White Ivory
Panel Color : White
Power(KW) : 2
Rated Water Pressure: 8 Bars



Longer life in toughest water conditions with Blue Diamond® glass lined tank



Maximum energy savings with BEE 5 Star rating



Superior performance with incoloy heating element



Temperature Control Knob
Easy temperature settings.



Long-lasting Anode Rod
2X lifespan as compared to normal magnesium rod.



Advanced PUF Insulation
High energy efficiency and power savings.



Inner Tank	Extended Warranty* on Heating Element	Comprehensive
7 years	2+1 years	2 years

Storage Water Heaters

Product Dimensions

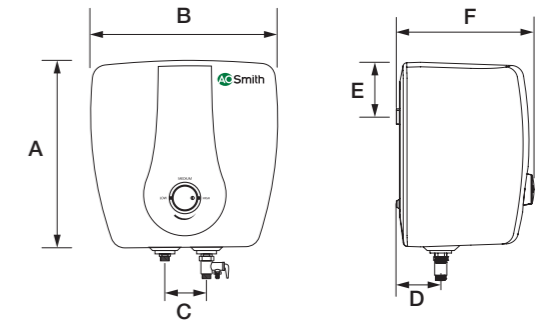

All Dimensions in mm

Model Name	A	B	C	D	E	F
SAS-PLUS-006	317	317	100	85	105	258
SAS-PLUS-010	373	373	100	95	120	277
SAS-PLUS-015	373	373	100	125	130	348
SAS-PLUS-025	444	444	100	125	135	383

A. O. Smith ColourMatch System®



* Refer page 32 for more details

Colours shown are only indicative and may vary from actual colours available.



BIG ON SLEEKNESS

With its sleek design and horizontal orientation, HAS-X and HAS-X1 are designed to fit into tight spaces. Available in RHS and LHS variants to facilitate hassle free installation.

HAS-X & HAS-X1



Capacity : 15L, 25L, 35L, 50L

Product Color : White

Power(KW) : 2

Rated Water Pressure: 8 Bars



Longer life in toughest water conditions with Blue Diamond® glass lined tank



Temperature Control Knob
Easy temperature settings.



Glass-Coated Incoloy Heating Element
Resistant to scale formation.



Advanced PUF Insulation
High energy efficiency and power savings.



Long-lasting Anode Rod
2X lifespan as compared to normal magnesium rod.



Inner Tank	Extended Warranty* on Heating Element	Comprehensive
7 years	2+2 years	2 years

Storage Water Heaters

Product Dimensions

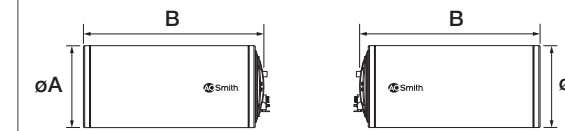

HAS-X / HAS-X1 RHS

HAS-X / HAS-X1 LHS

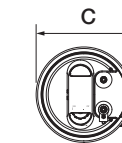

Typical Side View

All Dimensions in mm

Model Name	A	B	C
HAS-X1-015 HAS-X1-015-LHS	338	509	352
HAS-X-015 HAS-X-015-LHS	320	492	334
HAS-X1-025 HAS-X1-025-LHS	338	704	352
HAS-X-025 HAS-X-025-LHS	320	694	334
HAS-X-035 HAS-X-035-LHS	395	659	408
HAS-X-050 HAS-X-050-LHS	395	875	408



BUILT FOR HIGH CAPACITY

With Glass coated Incoloy heating element, Blue Diamond Glass lined tanks coupled with a sturdy outer body ensures superior performance, extended durability and large capacity designed for years to come.

HSE-HAS-X



Capacity : 70L, 100L
Product Color : White
Power(KW) : 3
Rated Water Pressure: 8 Bars



Longer life in toughest water conditions with Blue Diamond® glass lined tank



Temperature Control Knob
Easy temperature settings.



Glass-Coated Incoloy Heating Element
Resistant to scale formation.



Advanced PUF Insulation
High energy efficiency and power savings.



Long-lasting Anode Rod
2X lifespan as compared to normal magnesium rod.



Inner Tank	Extended Warranty* on Heating Element	Comprehensive
7 years	2+2 years	2 years

Storage Water Heaters

Product Dimensions

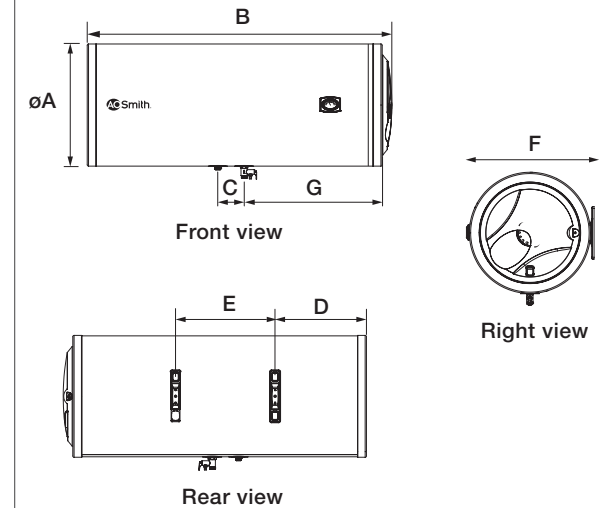

All Dimensions in mm

Model Name	A	B	C	D	E	F	G
HSE-HAS-070	465	900	100	255	300	490	450
HSE-HAS-100	465	1155	100	355	380	490	540



EPITOME OF DURABILITY

Sturdy tank construction coupled with rust proof outer body ensures a lifetime performance. Saves on energy bills with 5 Star rating.

HSE-VAS-X



Capacity : 15L, 25L, 35L, 50L

Product Color : White

Power(KW) : 2

Rated Water Pressure: 8 Bars



Longer life in toughest water conditions with Blue Diamond® glass lined tank



Temperature Control Knob
Easy temperature settings.



Glass-Coated Incoloy Heating Element
Resistant to scale formation.



Advanced PUF Insulation
High energy efficiency and power savings.



Long-lasting Anode Rod
2X lifespan as compared to normal magnesium rod.



Inner Tank	Extended Warranty* on Heating Element	Comprehensive
7 years	2+1* years	2 years
	2+2* years	2 years

Storage Water Heaters

Product Dimensions

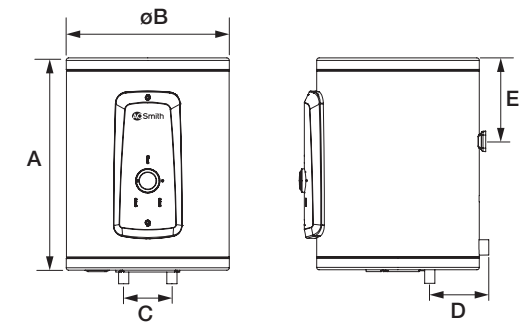

All Dimensions in mm

Model Name	A	B	C	D	E
HSE-VAS-X-015	440	338	100	123	173
HSE-VAS-X-025	644	338	100	123	191
HSE-VAS-X-035	615	395	100	152	193
HSE-VAS-X-050	832	395	100	152	193

*Extended Warranty on Heating Element: 2+1 years on HSE-VAS-X-15/25 & 2+2 years on HSE-VAS-X-35/50.



MiniBot® | Instant Water Heater

Why settle for ordinary?

The MiniBot® instant water heater is a masterpiece with an outstanding design and cutting edge technology, redefining the instant water heater category. You may say it's a perfect balance of form and function that will make your bathroom look magnificent and extraordinary. That's why we say... **Why Settle For Ordinary?**



3 litre capacity

MiniBot®



Capacity : 3L

Product Color : White | Black

Power(KW) : 3 | 4.5

Rated Water Pressure: 8 Bars



Beautifies your bathroom with modern minimalistic design



Get instant hot water with glass coated heating element



Longer life in toughest water conditions with Blue Diamond® glass lined tank



Designed for high rise buildings with 8 bar pressure rating



Stronger construction quality with tank thickness of 2 mm, 2X compared to an ordinary instant water heater



Inner Tank	Extended Warranty* on Heating Element	Comprehensive
5 years	2+1 years	2 years

Instant Water Heater

Product Dimensions

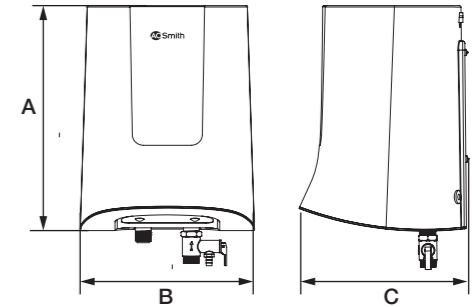

All Dimensions in mm

Model Name	A	B	C
MiniBot®	317	236	228

*Extended Warranty: Registration of Extended Warranty is valid if customer registers the product within 60 days of purchase. For more details log on to www.aosmithindia.com

FAST-ON[®]

Instant Water Heater

**Mini Size,
Max Power.**



**MOST
COMPACT**

Instant Water Heater*

*As compared with all leading national brands of water heaters in terms of height in 3 Litres tank capacity.



FAST-ON[®]



Capacity : 3L

Product Color : White | Black

Power(KW) : 3 | 4.5

Rated Water Pressure: 8 Bars



Easily fits into your bathroom or kitchen with its Super Compact Size, minimalistic design and beautiful aesthetics



Get instant hot water with high powered heating element



Longer life in toughest water conditions with Blue Diamond[®] glass lined tank



Designed for high rise buildings with 8 bar pressure rating



Stronger construction quality with tank thickness of 2 mm, **2X compared** to an ordinary instant water heater



Inner Tank	Warranty* on Heating Element	Comprehensive
5 years	2 years	2 years

Instant Water Heater

A powerful instant water heater that gives you hot water in no time with a super compact design. It's perfect for your bathroom or kitchen.

Product Dimensions

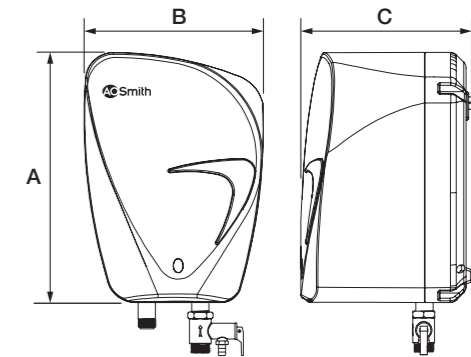

All Dimensions in mm

Model Name	A	B	C
FAST-ON [®]	306	219	209

BEAUTY ON THE OUTSIDE. BEAST ON THE INSIDE.

Our water heaters aren't just impressive on the outside. They're equally world-class on the inside. That's why you get a 7-year warranty* on the tank, a 4-year extended warranty* on the heating element and a 2-year comprehensive product warranty* that promises safety and longevity.



Ti Steel Tanks

A. O. Smith water heaters now come with a specially designed Titanium steel tank that ensures sturdy construction, longer life and superior quality that is unmatched. The Titanium steel combined with our patented Blue Diamond® coating is the most technologically advanced combination & gives A. O. Smith water heaters resistance to corrosion even in hard waters.



Advanced PUF Technology

The advanced PUF injection ensures uniform and high density foam distribution. Complete coverage of the PUF in between the tank & outer jacket greatly reduces the heat loss. This ensures maximum energy efficiency and power savings.



Fold Back Heating Element

Fits the shape of the tank, ensuring uniform heating and continuous and maximum availability of hot water.

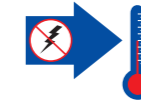

Thermal Cut-Out for Safety

If the water temperature exceeds the highest preset limit then this automatically cuts off the power supply to the water heater for your family's safety.

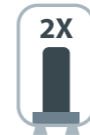

Long-Lasting Anode Rod

A customised alloy that works even in hard water conditions to protect the tank and has 2X lifespan as compared to a magnesium alloy commonly used in most water heaters.

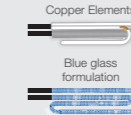

Glass-Coated Heating Element*

Incoloy heating element protected by glass coating to prevent scale formation and extend the life of heating element.



Multi-Function Safety Valve

Four levels of built-in safety through pressure relief valve, non-return valve, drain valve and vacuum release valve.

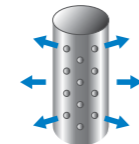

Efficient Inlet Water Diffuser

Efficient Inlet Water Diffuser breaks the incoming water jet into smaller streams, changing water flow from vertical to horizontal direction. Supplying more and continuous hot water at every point.

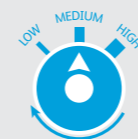

Thermostat

Helps in setting the temperature of your water for a relaxing bath.



Wire Harness and Power Cord

Complying to the stringent standards of UL 1015 for wires, IS 694 for cables and IS 1293 for plug.







*Features may vary as per model

PRODUCTS	MECHANICAL									INSTANT	
	SZS	SDS-PLUS	SGS-PLUS	SAS-PLUS	HAS-X	HAS-X1	HSE-HAS	HSE-VAS-X	HSE-VBS-X	FAST-ON	MiniBot
											
CONVINEINCE Blue Diamond® glass lining	✓	✓	✓	✓	✓	✓	✓	✓	✓	✓	✓
Glass coated heating element	✓	✓	✓	-	✓	✓	✓	✓	✓	✓	✓
LED Indicators	✓	✓	✓	✓	✓	✓	✓	✓	✓	✓	✓
Temperature control knob	✓	✓	✓	✓	✓	✓	✓	✓	✓	-	-
Express Heat	-	-	✓	-	-	-	-	-	✓	✓	✓
Thermal cut-out	✓	✓	✓	✓	✓	✓	✓	✓	✓	✓	✓
Anode rod	✓	✓	✓	✓	✓	✓	✓	✓	✓	✓	✓
Safety valve	✓	✓	✓	✓	✓	✓	✓	✓	✓	✓	✓
Adjustable Thermostat	✓	✓	✓	✓	✓	✓	✓	✓	✓	-	-
Mounting	Wall	Wall	Wall	Wall	Wall & Loft	Wall & Loft	Wall	Wall	Wall	Wall	Wall

PRODUCTS	DIGITAL
	SZS-DG
	
DIGITAL Blue Diamond® glass lining	✓
Glass coated heating element	✓
Digital Display	✓
Remote	Wireless
Energy Meter	✓
Digital Clock	✓
Digital Temperature Setting	✓
Smart Timer Mode (Auto on/off)	✓
Thermal cut-out	✓
Anode rod	✓
Safety valve	✓
Adjustable Thermostat	✓
Mounting	Wall

HOW TO CHOOSE YOUR WATER HEATER.

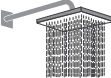
Capacity is the primary criteria which depends on the kind of usage.

<p>Kitchen</p>  <p>Suggested Capacity in Litres 3 / 6</p>	<p>Bucket</p>  <p>Suggested Capacity in Litres 10 / 15</p>	<p>Normal shower</p>  <p>Suggested Capacity in Litres 25</p>	<p>Body shower panel</p>  <p>Suggested Capacity in Litres 35 / 50</p>
<p>Rain shower</p>  <p>Suggested Capacity in Litres 50 / 70</p>	<p>Bath tub</p>  <p>Suggested Capacity in Litres 100 / 200</p>	<p>Jacuzzi</p>  <p>Suggested Capacity in Litres Above 200</p>	

A. O. Smith Colour Match System®

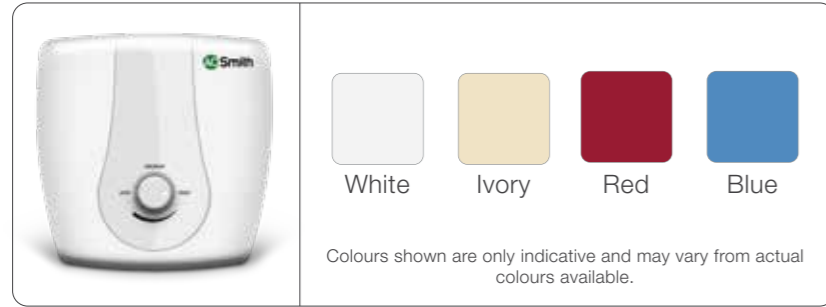

A. O. Smith Colour Match System® allows your Water Heater to match the colours of your bathroom. The product of your choice comes with either white or ivory body colours, along with the coloured front panels as in the following table.

Model Name	SAS PLUS	SDS* PLUS	SGS* PLUS
Decorative front panel (Service Cover)	White or Ivory	Blue or Red	Red
Body Colour	White or Ivory	White or Ivory	White or Ivory

* You have the option of Availing this panel to match your bathroom decor at a no cost. This option is available only one time after purchase (for SDS and SGS models).

You have the option of changing this panel to match your bathroom decor at a nominal cost (for SAS models).

Follow instructions in the user manual to change the panel. Alternatively you can get the panel fixed by qualified AO Smith technician at a nominal cost.

Call the A. O. Smith Customer Care Centre [1800-103-2468/1860-500-2468] or visit www.aosmithindia.com to register your product within 60 days of purchase and ask for one of the Decorative Front Panel colour options.

DISCLAIMER

- Product images / color shown may vary from actual model. Design, feature and specifications mentioned are subject to change without notice. Applicable for all models.
- Anode : AO Smith customized anode has a minimum of 2X more life when compared to a regular magnesium anode of similar dimensions, when tested under standard lab test conditions.
- Blue diamond : AO Smith Blue Diamond glass lining has a minimum of 2X more durability when compared to a regular glass coating, when exposed to hot water in standard lab test conditions.

WARRANTY

Product Warranty

Your A. O. Smith Water Heater is warranted against defects arising from faulty design, workmanship and materials for a period of 24 months from the date of the invoice, subject to the following conditions:

- The customer will notify the Company promptly about defects noticed and give the Company or its Authorised Service Provider adequate opportunity to inspect, test and remedy them, for which the customer will deposit the goods, if necessary, with the Company's Office/Authorised Service Provider along with the original invoice.
- Special warranty from the date of purchase is only applicable for the below mentioned components:

Tank	7 Years
Glass-Coated Heating Element	2 + 2 Years*
Product Warranty	2 Years



Applicable for **SGS-PLUS, SDS-PLUS, SZS, SZS-DG, HAS-X & HAS-X1, HSE-HAS-X, HSE-VAS-X-35/50 Models.**

Tank	7 Years
Heating Element	2 + 1 Years*
Product Warranty	2 Years

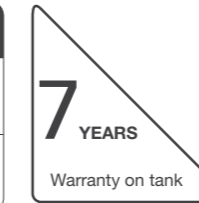

Applicable for **SAS-PLUS, HSE-VAS-X-15/25 Models.**

*Extended Warranty: Registration of Extended Warranty is valid if customer registers the product within 60 days of purchase. For more details log on to www.aosmithindia.com

WE'VE RAISED THE BAR. FOR WATER PURIFIERS TOO.

In addition to water heaters, we've also brought international standard water purifiers to India. Our range of water purifiers offer everything you've thought of, and more. Engineered with the finest technologies, our water purifiers are intuitive, efficient and beautiful. Whether it's top of the line, 5 star rated* A.O. Smith ProPlanet series, Green series, the invisible under the counter models Z2+ and X5+ or the UV models Z1 and X2, find one that best suits your needs.



Ordinary RO water purifiers use four glasses of water to make just one glass of clean water. But A. O. Smith water purifiers with Advance Recovery Technology™ (ART™) save 2X more water*. With high water recovery of 60% in ProPlanet series, you save more than 9000L of water annually*, which is potentially enough for 2 families of 4. Unlike ordinary RO purifiers, the water doesn't bypass the RO membrane. Instead, we pass 100% of the water through it. What this means is that all the water is purified with minimal wastage.